

**CYCLONE HAND HOIST PARTS LISTS**

Key No.	No. Req'd	Part Name	Capacity - Ton				
			¼ & ½	1	1½ & 2	5 & 6	8 & 10
			Part Number				
646-1	1	Frame with Upper Hook (Includes Items 646-1A thru 646-1F and 646-15)-Not Shown	C701	C702	--		
646-1A	1	Frame	45612C		--		
646-1B	1	Upper Hook (Includes Latch) - Latch Type	45601	45602	--		
646-1B	1	Upper Hook - Latchlok Type	1020	1022	--		
646-1C	2	Upper Hook Washer	45930		--		
646-1D	1	Upper Hook Collar	41350	27359	--		
646-1E	1	Upper Hook Collar Pin	45940	45941	--		
646-1F	1	Upper Hook Sleeve	45930	--	--		
646-2A	1	Load Chain Guide	45047	45048	--		
646-2B	2	Load Chain Guide Screw	945807		--		
646-2C	2	Load Chain Guide Screw L.W.	945851		--		
646-3A	1	Stripper	45043		--		
646-3B	1	Stripper Screw	983745		--		
646-3C	1	Stripper Screw L.W.	940830		--		
646-4	1	Handwheel Shaft and Pinion with Bearings (Items 646-4A thru 646-4D-Not Shown)	C703	C704	--		
646-4A	1	Handwheel Shaft and Pinion	45353	45354	--		
646-4B	1	Pinion Shaft Bearing (Handwheel End)	88437		--		
646-4C	1	Pinion Shaft Bearing (Gear End)	88444		--		
646-4D	1	Handwheel Shaft Snap Ring	45873		--		
646-5	1	Pawl			45038	--	
646-5A	1	Pawl Bushing			45735	--	
646-6	1	Pawl Retaining Washer			45910	--	
646-7	1	Pawl Stud Snap Ring			45767	--	
646-8	1	Pawl Spring			45730	--	
646-9	1	Brake Assembly (Items 646-9A, 646-9B and 646-9CD)-Not Shown			C705	--	
646-9A	1	Friction Hub			45007	--	
646-9B	2	Friction Washer	45741 For Units With Load Limiters, 45831 For Units Without Load Limiters				
646-9CD	1	Ratchet with Bushing			45614	--	
646-9D	1	Ratchet Bushing			45718	--	
646-10	1	Non-Load Limiter Handwheel			46699	--	
646-11	1	Handwheel Shaft Nut Washer			45915	--	
646-12	1	Handwheel Shaft Nut			931717	--	
646-13	1	Friction Hub Key			45770	--	
646-14	1	Handwheel Cover			46005	--	
646-14A	1	Cover Label	946753		--		
646-15	1	Operating Instruction Label (See page 16)-Not Shown			946900	--	
646-15A	3	Handwheel Cover Screw			982698	--	
646-16	1	Liftwheel with Bearings (Items 646-16A thru 646-16D) -Not Shown	C706	C707	--		
646-16A	1	Liftwheel	45364	45365	--		
646-16B	1	Liftwheel Bearing (Handwheel End)	88489		--		
646-16C	1	Liftwheel Bearing (Gear End)	88429		--		
646-16D	1	Liftwheel Snap Ring	45871		--		
646-17A	1	Frame Bearing Retainer	45750		--		
646-17B	2	Frame Bearing Retainer Screw	987716		--		
646-18	1	Liftwheel Gear	45061	45060	--		
646-19	1	Liftwheel Gear Key	989101		--		
646-20	1	Liftwheel Gear Snap Ring	68703		--		
646-24	1	Gear Cover with Capacity Insert	C708 for ¼ Ton, C721 for ½ Ton and C722 for 1 Ton				
646-24A	1	Capacity Insert	46705 (¼ Ton)		--		
			46706 (½ Ton)		--		
			46707 (1 Ton)		--		
646-24B	2	Capacity Insert Pin			988271	--	
646-24C	3	Gear Cover Screw	987322		--		
646-24D	1	Gear Cover Gasket	45745		--		
646-25A	1	Loose End Screw	946801		--		
646-25B	1	Loose End Screw Washer	954807		--		
646-29	1	Lower Hook and Block Assembly-Latch Type Hook	28683	45668	--		
646-29A	1	Lower Hook with Latch-Latch Type Hook	28686	35611	--		
646-29A	1	Lower Hook-Latchlok Type Hook	1051		--		
646-29B	1	Hook Block Body	45401		--		
646-29D	1	Lower Hook Washer	945921		--		
646-29E	1	Lower Hook Thrust Bearing	88485		--		
646-29F	1	Lower Hook Nut	982526		--		
646-29G	1	Lower Hook Nut Pin	983772		--		
646-29H	1	Lower Hook Chain Block	28007	45016	--		
646-29J	1	Hook Block Pin	45943		--		
646-30	1	Load Chain (Specify Lift or Length Req'd)	85839	85841	--		
646-31	1	Hand Chain (Specify Lift or Length Req'd)			85808	--	
646-32	1	Warning Tube			946735	--	
646-38	2	Latch Kit	45661	45662	--		
646-45	1	Hand Chain Connecting Link			945490	--	
646-101	1	Frame with Upper Hook (Includes Items 646-101A thru 646-101E and 646-15)-Not Shown			C730	--	
646-101A	1	Frame			45613C	--	

## CYCLONE HAND HOIST PARTS LIST

Key No.	No. Req'd	Part Name	Capacity - Ton					
			1/4 & 1/2	1	1-1/2 & 2	3 & 4	5 & 6	8 & 10
			Part Number					
646-101B	1	Upper Hook (Includes Latch) Latch Type	--		45604		--	
646-101B	1	Upper Hook-Latchlok Type	--		1023		--	
646-101C	2	Upper Hook Washer	--		45918		--	
646-101D	1	Upper Hook Collar	--		35478		--	
646-101E	1	Upper Hook Collar Pin	--		45946		--	
646-102A	1	Load Chain Guide	--			45049		
646-102B	3	Load Chain Guide Screw	--			945815		
646-102C	3	Load Chain Guide Screw L.W.	--			45852		
646-103A	1	Stripper	--			45420		
646-103B	2	Stripper Screw	--			982709		
646-104	1	Handwheel Shaft and Pinion with Bearings (Items 646-104A, 646-104B and 646-104C) - Not Shown	--			C710 For 1-1/2 & 3 Ton, C711 For 2, 4, 5, 6, 8 & 10 Ton		
646-104A	1	Handwheel Shaft and Pinion	--		45355 for 1-1/2 & 3 Ton,	45356 for 2, 4, 5, 6, 8 & 10 Ton		
646-104B	1	Handwheel Shaft Bearing (Handwheel End)	--			88437		
646-104C	1	Handwheel Shaft Bearing (Pinion End)	--			83671		
646-116	1	Liftwheel with Bearings (Items 646-116A thru 646-116E) - Not Shown	--			C712		
646-116A	1	Liftwheel	--			45057		
646-116B	1	Liftwheel Bearing (Handwheel End)	--			88445		
646-116C	1	Liftwheel Bearing (Gear End)	--			83669		
646-116D	1	Liftwheel Snap Ring	--			45766		
646-116E	1	Liftwheel Bearing Retaining Ring (Gear End)	--			46800		
646-118	1	Liftwheel Gear	--			45008		
646-119	2	Liftwheel Dowel Pin	--			45771		
646-121	1	Intermediate Gear and Pinion with Bearings (Items 646-121A, 646-121B and 646-121C) - Not Shown				C713 for 1 1/2 & 3 Ton, C714 for 2, 4, 5, 6, 8 & 10 Ton		
646-121A	1	Intermediate Gear & Pinion	--			45014 for 1-1/2 & 3 Ton (7 & 45 Teeth) 45015 for 2, 4, 5, 6, 8 & 10 Ton (7 & 47 Teeth)		
646-121B	1	Intermediate Gear Bearing (Pinion End)	--			83682		
646-121C	1	Intermediate Gear Bearing (Cover End)	--			88437		
646-122	2	Gear Cover Dowel	--			46730		
646-124	1	Gear Cover with Capacity Insert				C715 for 1-1/2 Ton, C723 for 2 Ton, C724 for 3 Ton, C725 for 4 Ton, C726 for 5 Ton, C727 for 6 Ton, C728 for 8 Ton & C729 for 10 Ton		
646-124A	1	Capacity Insert				46708 (1-1/2 Ton), 46709 (2 Ton), 46710 (3 Ton) 46711 (4 Ton), 46712 (5 Ton), 46713 (6 Ton), 46714 (8 Ton), 46715 (10 Ton)		
646-124B	2	Capacity Insert Pin	--			988271		
646-124C	3	Gear Cover Screw	--			983732		
646-124D	1	Gear Cover Gasket	--			46704		
646-125A	1	Loose End Screw	--			945815		
646-125B	1	Loose End Screw L.W.	--			945852		
646-125C	1	Loose End Screw Washer	--			954806		
646-129	1	Lower Hook and Block Assembly-Latch Type Hook	--		45669		--	
646-129A	1	Lower Hook with Latch-Latch Type Hook	--		45603		--	
646-129A	1	Lower Hook-Latchlok Type Hook	--		1024		--	
646-129B	1	Hook Block Body	--		45399		--	
646-129E	1	Lower Hook Thrust Bearing	--		88505		--	
646-129F	1	Lower Hook Nut	--		45382		--	
646-129G	1	Lower Hook Nut Pin	--		983779		--	
646-129H	1	Lower Hook Chain Block	--		45017		--	
646-129J	1	Hook Block Pin	--		45948		--	
646-130	1	Load Chain (Specify Lift or Length Req'd)	--			85864		
646-131	1	Hand Chain (Specify Lift or Length Req'd)				85808		
646-132	1	Load Limiter Complete				44602 for 1/4 Ton, 44601 for 1/2 Ton, 44600 for 1 thru 10 Ton		
646-133	1	Handwheel Sub-Assembly				45675		
646-134	1	Load Limiter Hub				45012		
646-135	2	Friction Washer				45886		
646-136	1	Steel Washer				45032		
646-137	1	Spring Washer				45888		
646-138	1	Lockwasher				45033		
646-139	1	Nut				45737		
646-144	2	Latch Kit	--		45663		--	
646-201B	1	Upper Hook (Includes Latch)-Latch Type	--			45607	45606 (5T.) 40607 (6T.)	45609
646-201B	1	Upper Hook-Latchlok Type	--			1025	1027	1028
646-201C	2	Upper Hook Washer	--			40736		988005
646-201E	1	Upper Hook Nut Pin	--			983787		983788
646-201F	1	Upper Hook Nut	--			940834		945836
646-206	2	Latch Kit	--			45664	45664 (5T.) 45665 (6T.)	*45697
646-229	1	Lower Hook Block Assembly - Not Shown				45670 for 3 Ton, 45615 for 4 Ton. 45616 for 5 Ton, 45617 for 6 Ton 45619 for 8 & 10Ton		
646-229A	1	Lower Hook (Includes Latch)-Latch Type	--			45605	45606 (5T.) 40607 (6T.)	45609
646-229A	1	Lower Hook-Latchlok Type	--			1026	1027	1028

\*NOTE: 8 ton units before serial no. S-A006GT used latch kit part number 45696.

## CYCLONE HAND HOIST PARTS LIST

Key No.	No. Req'd	Part Name	Capacity - Ton						
			1/4 & 1/2	1	1-1/2 & 2	3 & 4	5 & 6	8 & 10	
			Part Number						
646-229B	1	Lower Hook Sleeve	--	--	--	45394	45393	45410	
646-229G	1	Lower Hook Pin	--	--	--	983787		983788	
646-229K	1	Lower Hook Nut	--	--	--	940834		945836	
646-229L	1	Lower Hook Thrust Bearing	--	--	--	88507		88511	
646-233A	1	Hoist Hanger (Also order 646-234A and 646-234B or 646-234D as applicable)	--	--	--	45090	45091	45094	
646-233B	1	Hoist Hanger Set Screw	--	--	--	986304		--	
646-234A	1	Hoist Hanger Screw (Also order 646-234B or 646-234D as applicable)	--	--	--	987223		987179	
646-234C	1	Hoist Hanger Screw Washer	--	--	--	945916		--	
646-234D	1	Hoist Hanger Screw Pin	--	--	--	983789		--	
646-235	1	Hoist Hanger Screw Sleeve	--	--	--	45391		--	
646-236	1	Hoist Hanger Sheave Cap (Tapped)	--	--	--			45123	
646-237	1	Hoist Hanger Sheave Cap (Drilled)	--	--	--			45124	
646-238	1	Hoist Hanger Chain Anchor	--	--	--			45134 (8T.)	
646-239	1 or 2	Hoist Hanger Sheave	--	--	--	45085		45106	
646-241	1 or 2	Hoist Hanger Bearing	--	--	--			88542	
646-242	2	Hoist Hanger Sheave Bearing	--	--	--	83670		--	
646-243	1	Hoist Hanger Snap Ring	--	--	--	45765		--	
646-244	2	Hoist Hanger Bearing Retainer	--	--	--	45151		--	
646-245	2	Hoist Hanger Sheave Shaft	--	--	--			45425	
646-246A	1	Hoist Hanger Sheave Shaft Bolt	--	--	--			89411	
646-246B	1	Hoist Hanger Sheave Shaft Bolt L.W.	--	--	--			987919	
646-247	2	Lower Hook Block (Also order Capacity Insert 646-275 For 5 & 6 Ton)	--	--	--	45107 (3T.) 45096 (4T.)	45101	--	
646-248	1	Lower Hook Block Body (Also order Capacity Insert 646-275)	--	--	--			45104	
646-249A	3	Lower Hook Block Screw	--	--	--	945796		45812	
646-249B	3	Hook Block Screw Nut	--	--	--	945820		945822	
646-249C	3	Hook Block Screw L.W.	--	--	--	945851		945853	
646-250	1 or 2	Hook Block Sheave	--	--	--	45086		45106	
646-252	1 or 2	Hook Block Sheave Bearing	--	--	--			88542	
646-253	2	Hook Block Sheave Bearing	--	--	--	83670		--	
646-254	1 or 2	Hook Block Sheave Shaft	--	--	--			45425	
646-256A	1	Hook Block Sheave Shaft Bolt	--	--	--			89411	
646-256B	1	Hook Block Sheave Shaft Bolt L.W.	--	--	--			987919	
646-257	1	Hook Block Sheave Cap (Tapped)	--	--	--			45123	
646-258	1	Hook Block Sheave Cap (Drilled)	--	--	--			45124	
646-259	1	Dead End Pin	--	--	--	45945		45944	
646-260	2	Reeving Caution Plate	--	--	--	45757		--	
646-275	1	Capacity Insert	46712 for 5 Ton, 46713 for 6 Ton, 45837 for 8 Ton & 45838 for 10 Ton						
646-276	1	I.D. Label	46203		46202				

Part Numbers for packaged lubricants used in Cyclone Hand and Low Headroom Trolley Hoists

Lubricant Usage	Type of Lubricant	Part Numbers and Packaged Quantities of Lubricants
Gears	Grease	28610 (1#can) 28632 (4#can)
Handwheel Threads	Spray	46698 (16 oz.)
Chain	Oil	28608 (1 pt. can) 28619 (1 gal. can)
Trackwheel Bearings	Grease	28610 (1#can) 28632 (4#can)
Trackwheel Gears	*Heavy Cup Grease	--
Handwheel Shaft	*Light Machine Oil	--

\*These are not furnished by CM in Packaged Quantities. When ordering lubricants, specify the type of lubricant, part number and packaged quantity required.

Touch-up Paints for Cyclone Hand and Low Headroom Trolley Hoists:  
 1. Hoist. Order \*(1) case (12-12 oz. Aerosol Cans) of Orange Touch-up paint Part Number 84190.  
 2. Trolley. Order \*(1) case (12-12 oz. Aerosol Cans) of Black Touch-up paint Part Number 84189.

\*Touch-up paints are only available in case quantities.

**NOTE: When painting hoists or trolleys, also order warning labels, identification labels, etc. that may be coated during painting.**





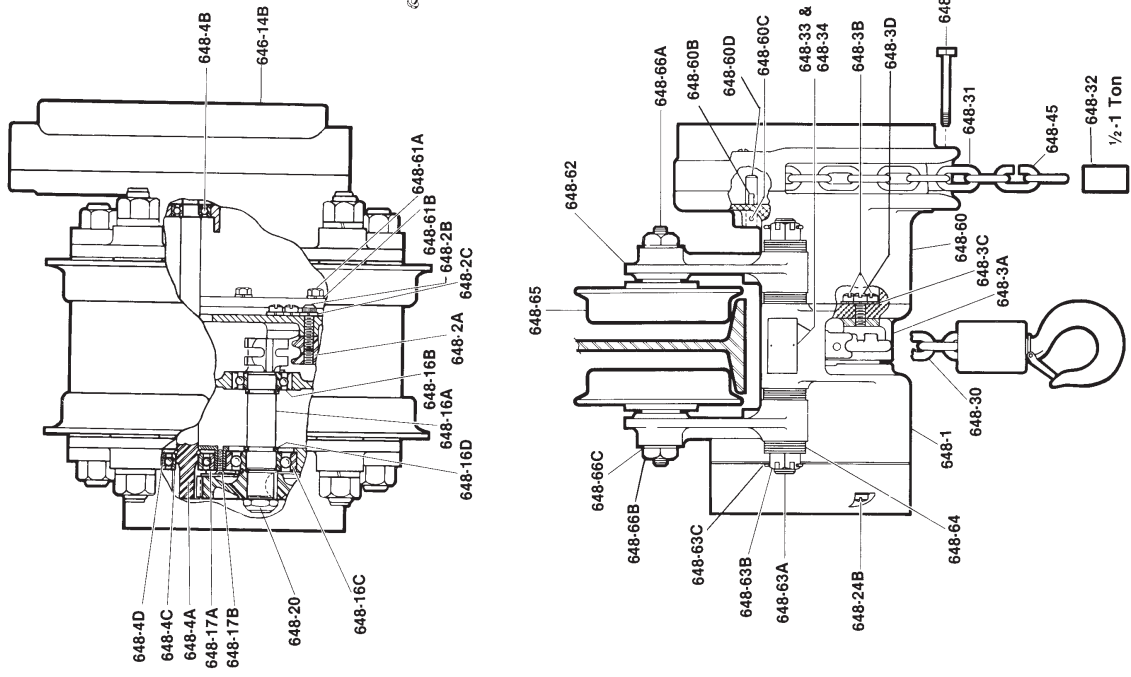

1/2-1 Ton

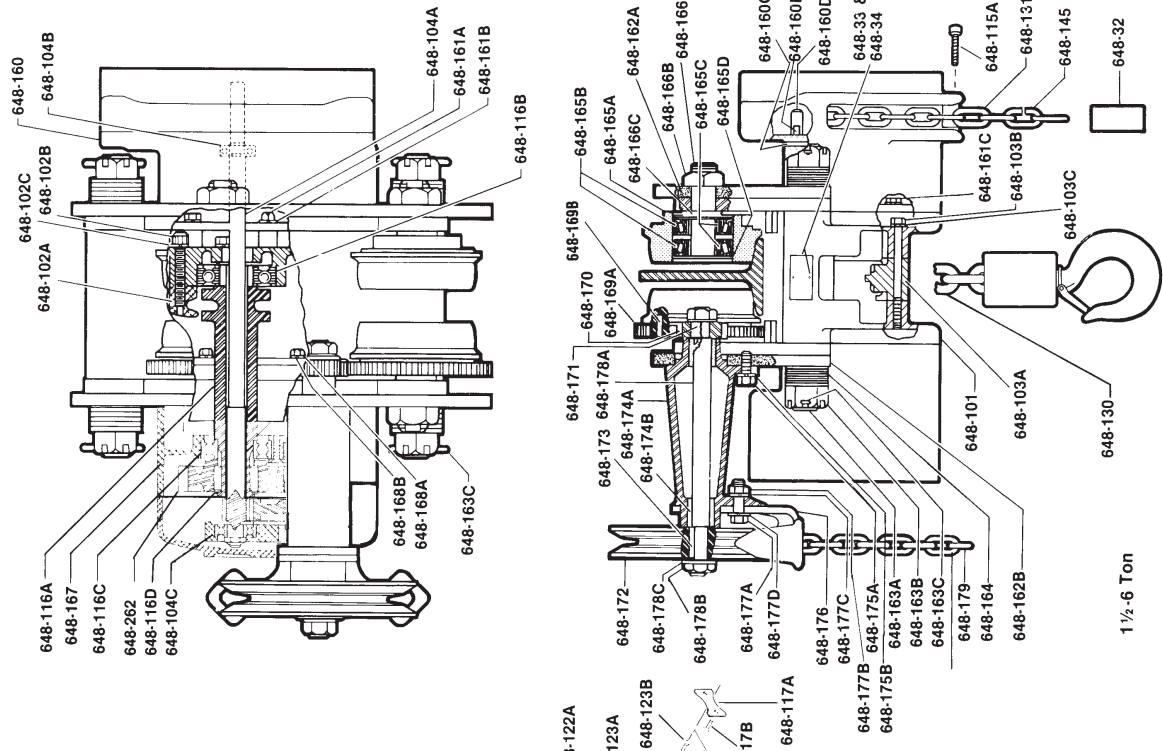

1 1/2-6 Ton

Figure 26. Cyclone Low Headroom Trolley Hoist

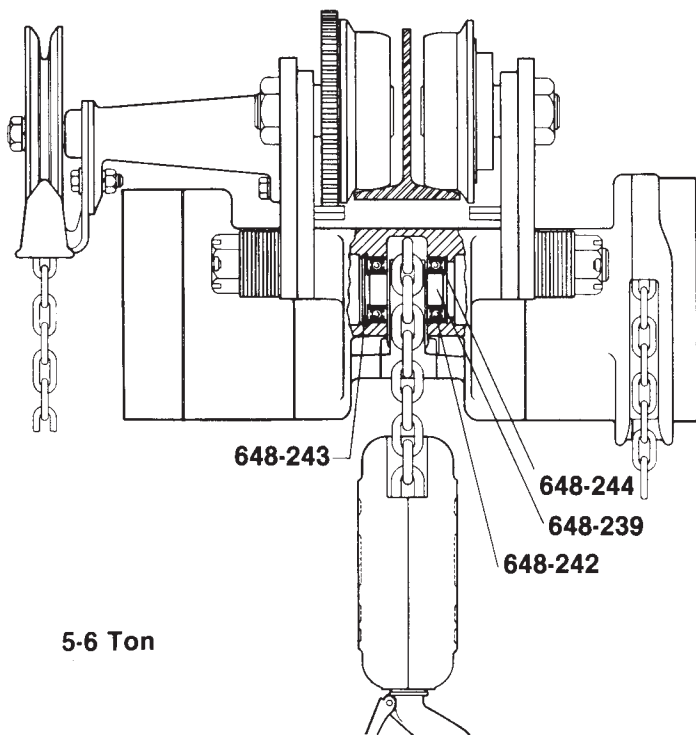
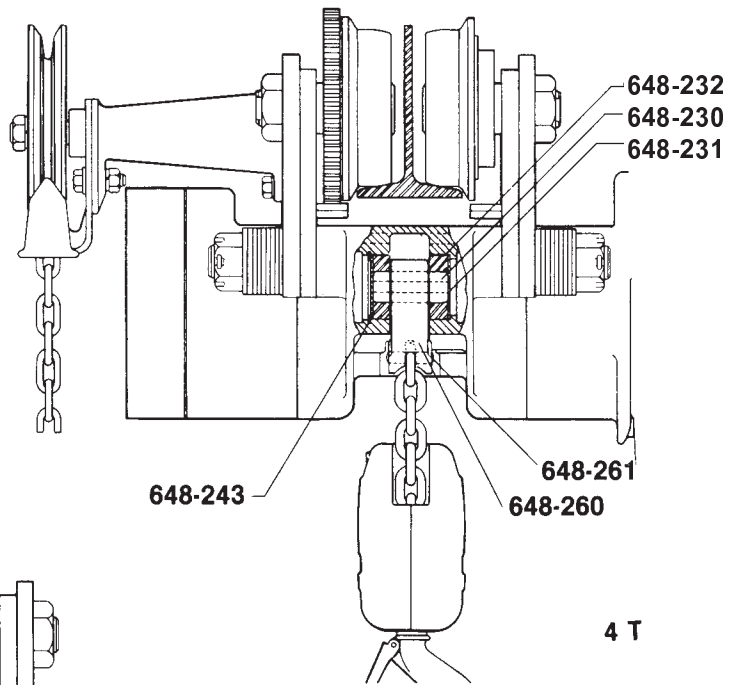
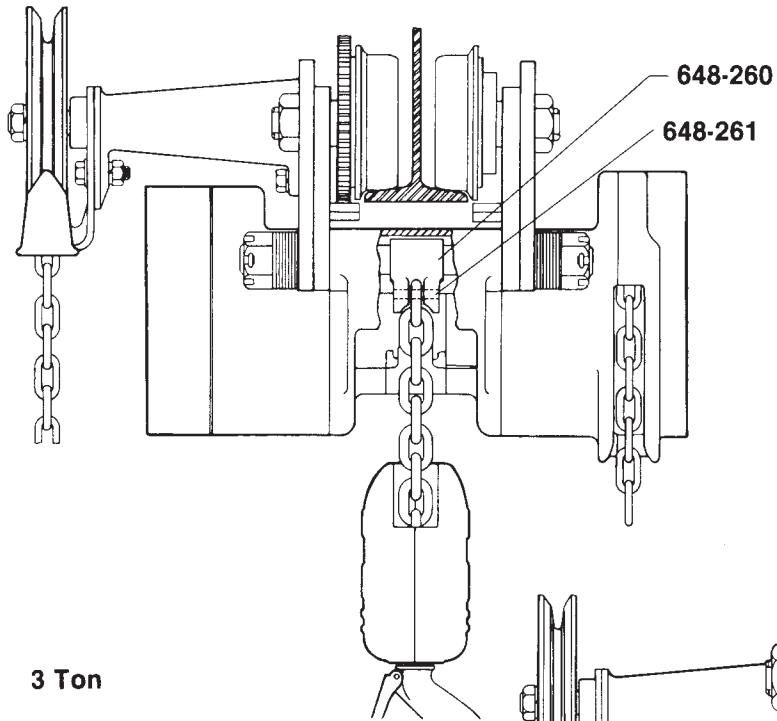

**CYCLONE LOW HEADROOM TROLLEY HOIST PARTS LIST**

Key No.	No. Req'd.	Part Name	Capacity - Ton		
			1/2 & 1	1-1/2, 2 & 3	4, 5 & 6
			Part Number		
648-1	1	Main Frame	48001C		--
648-2A	1	Load Chain Guide	45047 (1/2 T.) 45048 (1T.)		--
648-2B	2	Load Chain Guide Screw	982368		--
648-2C	2	Load Chain Guide Screw L.W.	945851		--
648-3A	1	Stripper	45043		--
648-3B	2	Stripper Screw-Long	982709		--
648-3C	3	Stripper Screw L.W.	Order 648-3B & 648-3D		--
648-3D	1	Stripper Screw-Short	987315		--
648-4A	1	Handwheel Shaft & Pinion	45357 (1/2 T.) 45358 (1 T.)		--
648-4B	1	Handwheel Shaft Bearing (Handwheel End)	88437		--
648-4C	1	Handwheel Shaft Bearing (Gear End)	88444		--
648-4D	1	Handwheel Shaft Snap Ring	45873		--
648-14B	1	Cover Label		946754	
648-15A	3	Handwheel Cover Screw	982698		--
648-16A	1	Liftwheel	48362 (1/2 T.) 48368 (1 T.)		--
648-16B	1	Liftwheel Bearing (Handwheel End)	88429		--
648-16C	1	Liftwheel Bearing (Gear End)	83674		--
648-16D	2	Liftwheel Snap Ring	48704		--
648-17A	1	Frame Bearing Retainer	48702		--
648-17B	2	Frame Bearing Retainer Screws	987716		--
648-20	1	Liftwheel Shaft Nut	945841		--
648-24B	3	Gear Cover Screw	987322		--
648-30	1	Load Chain (Specify Lift or Length Req'd.)	85839 (1/2 T.) 85841 (1 T.)		--
648-31	1	Hand Chain (Specify Lift or Length Req'd.)	85808		--
648-32	1	Warning Tube		946735	
648-33	1	I.D. Plate		45982	
648-34	2	Drive Screw		988271	
648-45	1	Hand Chain Connecting Link	945490		--
648-60	1	Front Frame with Pawl Stud and Pawl Spring Pin	48611C		--
648-60B	1	Pawl Spring Pin	983531		--
648-60C	1	Pawl Stud Pin	983494		--
648-60D	1	Pawl Stud	48376		--
648-61A	4	Front Frame Screw	987019		--
648-61B	4	Front Frame Screw L.W.	945851		--
648-62	2	Trolley Frame	*48005		--
648-63A	2	Suspension Bolt	*48371		--
648-63B	4	Suspension Bolt Nut	948803		--
648-63C	4	Suspension Bolt Cotter Pin	988343		--
648-64	-	Spacer Washer (Specify Quantity)	948700		--
648-65	4	Trackwheel	*50762		--
648-66A	4	Trackwheel Stud	*48300		--
648-66B	4	Trackwheel Stud Nut	*948804		--
648-66C	4	Trackwheel Stud Nut L.W.	*987924		--
648-101	1	Main Frame	--	**48010C for 1-1/2 & 2 Ton, 48010C for 3 Ton, 48013C for 4, 5 & 6 Ton	
648-102A	1	Load Chain Guide	--	45049	
648-102B	3	Load Chain Guide Screw	--	948805	
648-102C	3	Load Chain Guide Screw L.W.	--	45852	
648-103A	1	Stripper	--	48043	
648-103B	1	Stripper Screw	--	87055	
648-103C	1	Stripper Screw L.W.	--	987919	
648-104A	1	Handwheel Shaft and Pinion	--	45360 (10 Teeth, 18-7/64 Long) for 1-1/2 & 3 Ton, 45359 (8 Teeth, 18-7/64 Long) for 2 Ton and 45361 (8 Teeth, 20-47/64 Long) for 4, 5 & 6 Ton.	
648-104B	1	Handwheel Shaft Bearing (Handwheel End)	--	88437	
648-104C	1	Handwheel Shaft Bearing (Gear End)	--	83671	
648-112	2	Handwheel Shaft Nut	--	931717	
648-115A	3	Handwheel Cover Screw	--	982698	
648-116A	1	Liftwheel	--	48369	48370
648-116B	1	Liftwheel Bearing (Handwheel End)	--	83678	
648-116C	1	Liftwheel Bearing (Gear End)	--	83669	
648-116D	1	Liftwheel Snap Ring	--	45766	
648-117A	1	Frame Bearing Retainer	--	45751	
648-117B	2	Frame Bearing Retainer Screw	--	987716	
648-121D	1	Intermediate Gear and Pinion Nut	--	931717	
648-122A	1	Spider	--	45035	
648-122B	2	Spider Dowel	--	45430	
648-122C	3	Spider Attaching Screw	--	982689	
648-122D	3	Spider Attaching Screw L.W.	--	940830	

\*Part numbers listed are for trolleys that operate on 6" thru 12" S-beams. If trolley operates on 4" or 5" S-beam, part numbers are as follows: 48006 for 648-62 trolley frame, 48373 for 648-63A suspension bolt, 54732 for 648-65 trackwheel, 54731 for 648-66A trackwheel stud, 982521 for 648-66B trackwheel stud nut and 987921 for 648-66C trackwheel stud nut lockwasher.

\*\*Part number listed is for trolley that operates on 7" thru 15" S-beams. If trolley operates on 6" S-beam, part number is 48032C (1-1/2 & 2 Ton).



**CYCLONE LOW HEADROOM TROLLEY HOIST PARTS LIST**

Key No.	No. Req'd.	Part Name	Capacity - Tons		
			1/2 & 1	1-1/2, 2 & 3	4, 5 & 6
			Part Number		
648-123A	1	Spider Bearing Retainer	--	45752	
648-123B	2	Spider Bearing Retainer Screw	--	987716	
648-124A	1	Gear Cover	--	45717C	
648-124B	3	Gear Cover Screw	--	983732	
648-124C	1	Gear Cover Gasket	--	45746	
648-130	1	Load Chain (Specify Lift or Length Req'd.)	--	85864	
648-131	1	Hoist Hand Chain (Specify Lift or Length Req'd.)	--	85808	
648-145	1	Hand Chain Connecting Link	--	945490	
648-160	1	Front Frame with Pawl Stud and Pawl Spring Pin	--	48612C	
648-160B	1	Pawl Spring Pin	--	983531	
648-160C	1	Pawl Stud Pin	--	983535	
648-160D	1	Pawl Stud	--	48376	
648-161A	4	Front Frame Screw	--	987020	
648-161B	5	Front Frame Screw L.W.	--	945851	
648-161C	1	Front Frame and Stripper Screw	--	948807	987034
648-162A	1	Trolley Frame (Specify if for Plain or Geared)	--	48668	48670
648-162B	1	Trolley Frame (Specify if for Plain or Geared)	--	48667 for 1-1/2, 2 & 3 Ton Plain Trolley 46664 for 1-1/2, 2 & 3 Ton Geared Trolley 48669 for 4, 5 & 6 Ton Plain Trolley 46665 for 4, 5 & 6 Ton Geared Trolley	
648-163A	2	Suspension Bolt	--	58503 (1" Dia. x 12-1/4" Long) for 1-1/2, 2 and 3 Ton. 48372 (1-1/4 Dia. x 15" Long) for 4, 5 & 6 Ton	
648-163B	4	Suspension Bolt Nut	--	958818	945835
648-163C	4	Suspension Bolt Cotter Pin	--	988368	988381
648-164	--	Spacer Washer (Specify Quantity)	--	958726	948701
648-165A	4	Trackwheel	--	58162	58163
648-165B	8	Trackwheel Bearing Cup	--	88521	88556
648-165C	8	Trackwheel Bearing Cone	--	88525	88545
648-165D	8	Trackwheel Bearing Seal Washer	--	68918	68917
648-166A	4	Trackwheel Stud	--	58459	58540
648-166B	4	Trackwheel Stud Nut	--	982613	988192
648-166C	4	Trackwheel Stud Collar	--	58484	58492
648-167	1	Gear Housing	--	48015C	
648-168A	5	Gear Housing Screw	--	948806	948807
648-168B	5	Gear Housing Screw L.W.	--	945851	
648-169A	2	Trackwheel Gear	--	58548	58549
648-169B	4	Trackwheel Gear Pin	--	983503	
648-170	1	Trackwheel Pinion	--	46385	
648-171	1	Trackwheel Pinion Key	--	85446	
648-172	1	Trolley Handwheel	--	33143	
648-173	1	Trolley Handwheel Key	--	59967	
648-174A	1	Handwheel Bracket with Bushings	--	59616	
648-174B	2	Handwheel Bracket Bushing	--	58727	
648-175A	3	Handwheel Bracket Screw	--	987061	
648-175B	3	Handwheel Bracket Screw L.W.	--	945853	
648-176	1	Trolley Hand Chain Guide	--	58152	
648-177A	1	Trolley Hand Chain Guide Screw	--	987065	
648-177B	1	Trolley Hand Chain Guide Screw Nut	--	945822	
648-177C	1	Trolley Hand Chain Guide Screw L.W.	--	945853	
648-177D	1	Trolley Hand Chain Guide Screw Washer	--	986224	
648-178A	1	Trolley Handwheel Shaft	--	58504	
648-178B	2	Trolley Handwheel Shaft Nut	--	988095	
648-178C	2	Trolley Handwheel Shaft L.W.	--	986270	
648-179	1	Trolley Hand Chain (Specify Lift or Length Req'd)	--	85808	
648-180	1	Hand Chain Connecting Link	--	945490	
648-230	1	Hanger Chain Anchor Pin (4 Ton)	--	--	45425
648-231	2	Hanger Chain Anchor Pin Retainer (4 Ton)	--	--	48024
648-232	2	Hanger Chain Anchor Pin Block (4 Ton)	--	--	48393
648-239	1	Upper Sheave (5 & 6 Ton)	--	--	45085
648-242	2	Upper Sheave Bearing (5 & 6 Ton)	--	--	83670
648-243	1	Hanger Snap Ring (4 Ton)	--	--	45765
648-243	1	Upper Sheave Bearing Snap Ring (5 & 6 Ton)	--	--	45765
648-244	2	Upper Sheave Bearing Retainer (5 & 6 Ton)	--	--	45151
648-260	1	Hanger Chain Anchor	--	48019 (3 Ton)	48021 (4 Ton)
648-261	1	Dead End Pin (3 & 4 Ton)	--	45945 (3 Ton)	
648-262	1	Liftwheel Gear	--	45062	
648-263	1	Intermediate Gear and Pinion	--	45080 for 1-1/2 & 3 Ton, 45081 for 2, 4, 5 & 6 Ton	